



JEPPIAAR
ENGINEERING COLLEGE

JEPPIAAR NAGAR, CHENNAI – 600119

2021 REGULATION

DEPARTMENT OF ELECTRONICS & COMMUNICATION ENGINEERING.

EC3271 CIRCUITS ANALYSIS LABORATORY

(B.E II Semester Batch 2024-2028)

(Section A&B)

JEPPIAAR ENGINEERING COLLEGE
JEPPIAAR EDUCATIONAL TRUST

JEPPIAAR NAGAR

RAJIV GANDHI SALAI, CHENNAI-600 119



This is a certified Bonafide Record Book of.....

Register Number.....

Submitted for the Anna University practical Examination held
on.....in.....laboratory
during the year to

Signature of the Lab-in-charge

HOD/ECE

EXAMINERS:

Date.....

Internal.....

External.....

COURSE OBJECTIVES

The main learning objective of this course is to provide hands on training to the students in:

- ❖ To Gain the Knowledge KVL & KCL
- ❖ To understand the principle of Thevenin & Norton theorem
- ❖ To understand the principle of Superposition Theorems and maximum power transfer theorem.
- ❖ To learn the Frequency response of Series & Parallel RLC Circuits.
- ❖ To understand the working of Transient analysis of RL and RC circuits.

S.NO	LIST OF EXPERIMENTS
1	Verifications of KVL & KCL.
2	Verifications of Thevenin & Norton theorem.
3	Verification of Superposition Theorem.
4	Verification of maximum power transfer Theorem
5	Determination of Resonance Frequency of Series & Parallel RLC Circuits.
6	Transient analysis of RL and RC circuits.

COURSE OUTCOMES

Upon completion of this course, the students will be able to:

CO1	Verify KVL & KCL
CO2	Verify Thevenin & Norton theorem
CO3	Verify Superposition and Maximum transfer theorem
CO4	Analyze the performance of Series & Parallel RLC Circuits.
CO5	Design RL and RC circuits

JEPPIAAR ENGINEERING COLLEGE

Vision of the Institute	To build Jeppiaar Engineering College as an institution of academic excellence in technological and management education to become a world class University	
Mission of the Institute	M1	To excel in teaching and learning, research and innovation by promoting the principles of scientific analysis and creative thinking
	M2	To participate in the production, development and dissemination of knowledge and interact with national and international communities.
	M3	To equip students with values, ethics and life skills needed to enrich their lives and enable them to meaningfully contribute to the progress of society
	M4	To prepare students for higher studies and lifelong learning, enrich them with the practical and entrepreneurial skills necessary to excel as future professionals and contribute to Nation's economy

DEPARTMENT: ELECTRONICS AND COMMUNICATION ENGINEERING

Vision of the Department	To become a centre of excellence to provide quality education and produce creative engineers in the field of Electronics and Communication Engineering to excel at international level.	
Mission of the Department	M1	Inculcate creative thinking and zeal for research to excel in teaching-learning process
	M2	Create and disseminate technical knowledge in collaboration with industries
	M3	Provide ethical and value based education by promoting activities for the betterment of the society
	M4	Encourage higher studies, employability skills, entrepreneurship and research to produce efficient professionals thereby adding value to the nation's economy

PROGRAM OUTCOMES (PO)	PO 1	Engineering knowledge: Apply the knowledge of mathematics, science, engineering fundamentals, and an engineering specialization to the solution of complex engineering problems.
	PO 2	Problem analysis: Identify, formulate, review research literature, and analyze complex engineering problems reaching substantiated conclusions using first principles of mathematics, natural sciences, and engineering sciences.
	PO 3	Design/development of solutions: Design solutions for complex engineering problems and design system components or processes that meet the specified needs with appropriate consideration for the public health and safety, and the cultural, societal, and environmental considerations
	PO 4	Conduct investigations of complex problems: Use research-based knowledge and research methods including design of experiments, analysis and interpretation of data, and synthesis of the information to provide valid conclusions.
	PO 5	Modern tool usage: Create, select, and apply appropriate techniques, resources, and modern engineering and IT tools including prediction and modeling to complex engineering activities with an understanding of the limitations.
	PO 6	The engineer and society: Apply reasoning informed by the contextual knowledge to assess societal, health, safety, legal and cultural issues and the consequent responsibilities relevant to the professional engineering practice.
	PO 7	Environment and sustainability: Understand the impact of the professional engineering solutions in societal and environmental contexts, and demonstrate the knowledge of, and need for sustainable development.
	PO 8	Ethics: Apply ethical principles and commit to professional ethics and responsibilities and norms of the engineering practice.
	PO 9	Individual and team work: Function effectively as an individual, and as a member or leader in diverse teams, and in multidisciplinary settings.
	PO 10	Communication: Communicate effectively on complex engineering activities with the engineering community and with society at large, such as, being able to comprehend and write effective reports and design documentation, make effective presentations, and give and receive clear instructions.

	PO 11	Project management and finance: Demonstrate knowledge and understanding of the engineering and management principles and apply these to one's own work, as a member and leader in a team, to manage projects and in multidisciplinary environments.
	PO 12	Life-long learning: Recognize the need for, and have the preparation and ability to engage in independent and life-long learning in the broadest context of technological change.
PROGRAM EDUCATIONAL OBJECTIVES (PEOS)	PEO I	Produce technically competent graduates with a solid foundation in the field of Electronics and Communication Engineering with the ability to analyze, design, develop, and implement electronic systems.
	PEO II	Motivate the students for choosing the successful career choices in both public and private sectors by imparting professional development activities.
	PEO III	Inculcate the ethical values, effective communication skills and develop the ability to integrate engineering skills to broader social needs to the students.
	PEO IV	Impart professional competence, desire for lifelong learning and leadership skills in the field of Electronics and Communication Engineering.
PROGRAM SPECIFIC OUTCOMES (PSOs)	PSO 1	Design, develop and analyze electronic systems through application of relevant electronics, mathematics and engineering principles.
	PSO 2	Design, develop and analyze communication systems through application of fundamentals from communication principles, signal processing, and RF System Design & Electromagnetics.
	PSO 3	Adapt to emerging electronics and communication technologies and develop innovative solutions for existing and newer problems.

CO's-PO's & PSO's MAPPING

CO	PO1	PO2	PO3	PO4	PO5	PO6	PO7	PO8	PO9	PO10	PO11	PO12	PSO1	PSO2	PSO3
1	3	2	1	1	-	-	-	1	-	1	-	-	-	-	-
2	3	3	2	2	-	-	-	1	-	1	-	-	-	-	-
3	3	3	3	3	-	-	-	1	-	1	-	-	-	-	-
4	3	3	3	3	-	-	-	1	-	1	-	-	-	-	-
5	3	3	3	2	-	-	-	1	-	1	-	-	-	-	-
CO	3	3	3	2	-	-	-	1	-	1	-	-	-	-	-

1 - low, 2 - medium, 3 - high, - - no correlation



VERIFICATION OF THEVENIN'S THEOREM

EX. NO: 1(a)

AIM:

To verify the Thevenin's theorem for the given circuit.

APPARATUS REQUIRED:

S.NO	APPARATUS	TYPE	RANGE	QUANTITY
1	RPS	DC	(0-30)V	1
2	Resistor	-	1K Ω	3
3	Ammeter	DC	(0-10)mA	1
4	Bread board	-	-	1
5	Connecting wires	-	-	Few

THEORY:

THEVENIN'S THEOREM:

Any linear active network with output terminals C and D can be replaced by a single voltage source ($V_{Th} = V_{Oc}$) in series with a single impedance ($Z_{Th} = Z_i$).

V_{Th} is the Thevenin's voltage. It is the voltage between the terminals C and D on open circuit condition. Hence it is called open circuit voltage denoted by V_{Oc} .

Z_{Th} is called Thevenin's impedance. It is the driving point impedance at the terminals C and D when all the internal sources are set to zero. In case of DC Z_{Th} is replaced by R_{Th} .

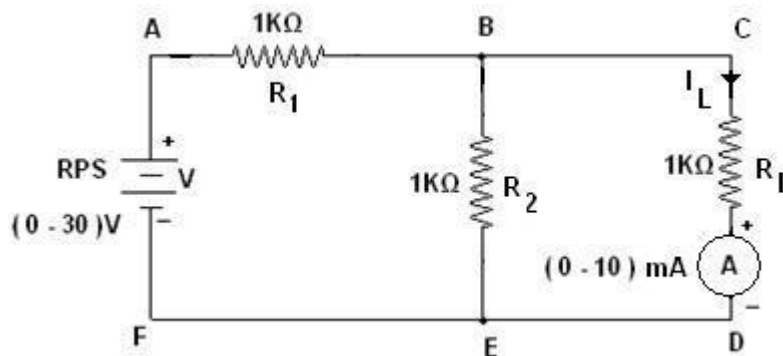

Circuit Diagram for Thevenin's Theorem

CALCULATION:

The Thevenin's equivalent circuit is,

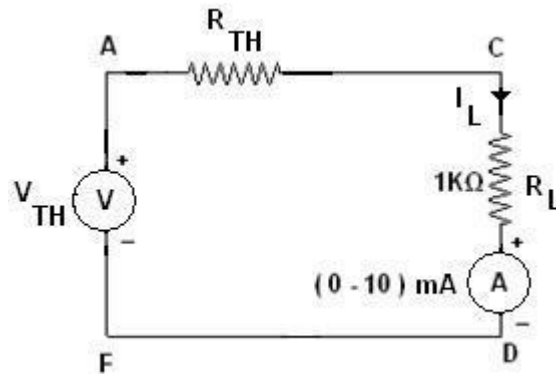

$$I_L = \frac{V_{TH}}{R_{TH} + R_L}$$

To Find R_{TH} :

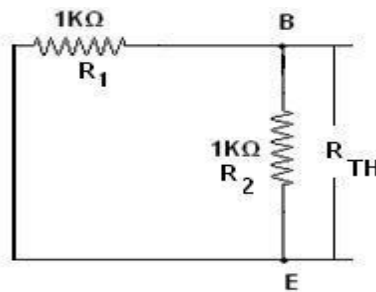

$$R_1 = 1K\Omega ; R_2 = 1K\Omega ;$$

$$R_{TH} = \frac{R_1 \cdot R_2}{R_1 + R_2}$$

To Find V_{TH} :

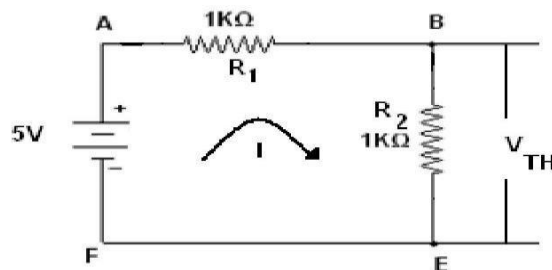

$$I = \frac{V}{R_T}$$

$$V_{TH} = V_{BE}$$

$$\therefore I_L = \frac{V_{TH}}{R_{TH} + R_L}$$

PROCEDURE:

1. The circuit connections are given as per the circuit diagram.
2. Switch ON the power supply.
3. Initially set 5V as input voltage from RPS.
4. The ammeter reading is noted and the value is tabulated.

Table:

Let V = 5V

S.NO	Voltage in Volts	Load Current in Amps	
		Theoretical Value	Practical Value

RESULT:

Thus the Thevenin's theorem for the given circuit is verified successful

NORTON'S THEOREM

EX. NO: 1(b)

AIM:

To verify the Norton's theorem for the given circuit.

APPARATUS REQUIRED:

S.NO	APPARATUS	TYPE	RANGE	QUANTITY
1	RPS	DC	(0-30)V	1
2	Resistor	-	1K Ω	3
3	Ammeter	DC	(0-10)mA	1
4	Bread board	-	-	1
5	Connecting wires	-	-	Few

THEORY:

NORTON'S THEOREM:

Any linear active network with output terminals C and D can be replaced by a single current source $I_{SC}(I_N)$ in parallel with a single impedance ($Z_{Th} = Z_n$).

I_{SC} is the current through the terminals C and D on short circuit condition. Z_{Th} is called Thevenin's impedance. In case of DC Z_{Th} is replaced by R_{Th} .

The current through impedance connected to the terminals of the Norton's equivalent circuit must have the same direction as the current through the same impedance connected to the original active network.

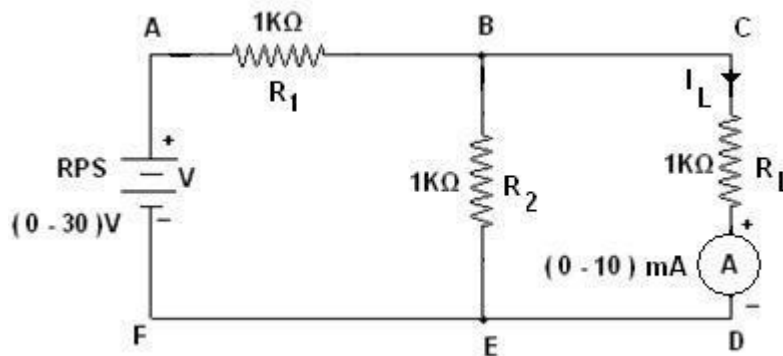

Circuit Diagram for Norton's Theorem

CALCULATION:

The Norton's equivalent circuit is,

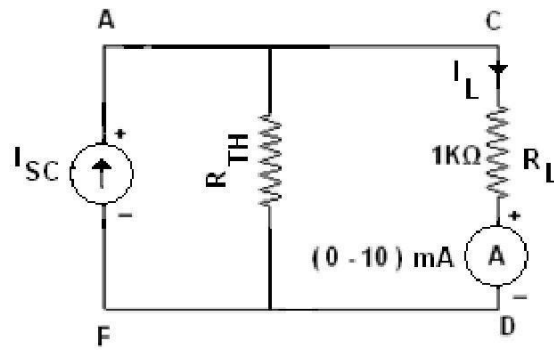

$$I_L = \frac{I_{SC} R_{TH}}{R_{TH} + R_L}$$

To Find R_{TH} :

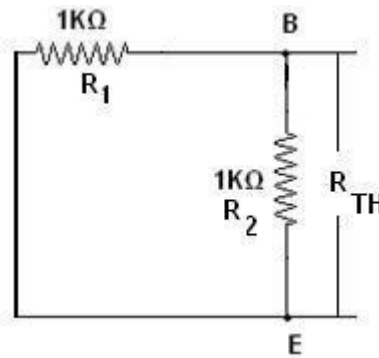

$$R_1 = 1K\Omega ; R_2 = 1K\Omega ;$$

$$R_{TH} = \frac{R_1 * R_2}{R_1 + R_2}$$

To Find I_{SC} :

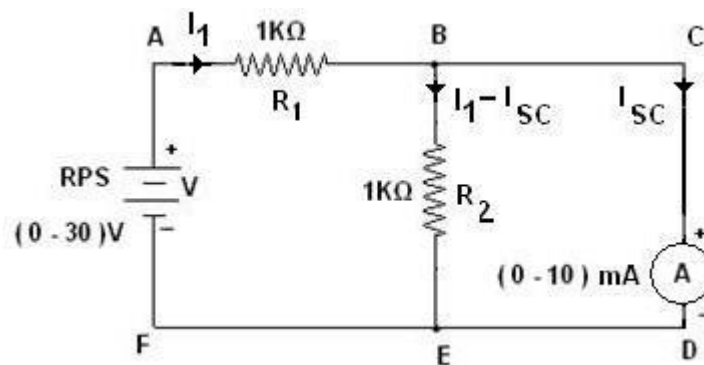

Let V=5V

In the loop ABEFA by applying KVL,

$$I_1 R_1 + (I_1 - I_{SC}) R_2 = V$$

$$I_1 \times 1 + (I_1 - I_{SC}) \times 1 = 5$$

$$2I_1 - I_{SC} = 5 \text{ -----(1)}$$

In the loop BCDEB by applying KVL,

$$(I_1 - I_{SC}) R_2 = V$$

$$(I_1 - I_{SC}) \times 1 = 0$$

$$I_1 - I_{SC} = 0 \text{ -----(2)}$$

From the equation (1) and (2),

$$\dot{I}_1 = I_{SC} = 5 \text{ mA}$$

$$I_L = \frac{I_{SC} \cdot R_{TH}}{R_{TH} + R_L}$$

PROCEDURE:

1. The circuit connections are given as per the circuit diagram.
2. Switch ON the power supply.
3. Initially set 5V as input voltage from RPS.
4. The ammeter reading is noted and the value is tabulated.

RESULT:

Thus the Norton's theorem for the given circuit is verified successfully.

KIRCHOFF'S VOLTAGE LAW

EX. NO: 2(a)

AIM:

To verify the Kirchoff's Voltage Law (KVL) for the given circuit.

APPARATUS REQUIRED:

S.NO	APPARATUS	TYPE	RANGE	QUANTITY
1	RPS	DC	(0-30)V	1
2	Resistor	-	1K Ω	3
3	Voltmeter	DC	(0-10)V	3
4	Bread board	-	-	1
5	Connecting wires	-	-	Few

FORMULA USED:

1. CURRENT DIVISION RULE:

$$I = \frac{\text{TOTAL CURRENT X OPPOSITE RESISTANCE}}{\text{TOTAL RESISTANCE}}$$

2. OHM'S LAW:

$$V=IR$$

Where, V = Voltage in Volts

I = Current in Amperes

R = Resister in Ohms

THEORY:

KIRCHOFF'S VOLTAGE LAW:

It states that the algebraic sum of all the voltages in a closed loop is equal to zero.

$$\sum V = 0$$

CALCULATION:

$$R_1 = 1\text{K}\Omega ; R_2 = 1\text{K}\Omega ; R_3 = 1\text{K}\Omega$$

$$R_T = R_3 + R_P$$

$$= R_3 + \frac{R_1 R_2}{R_1 + R_2}$$

$$I = \frac{V}{R_T}$$

Let $V = 5\text{V}$,

$$I_1 = \frac{I \cdot R_2}{R_1 + R_2}$$

$$V_1 = I_1 \cdot R_1$$

In the loop ABEFA,

$$V = V_3 + V_1$$

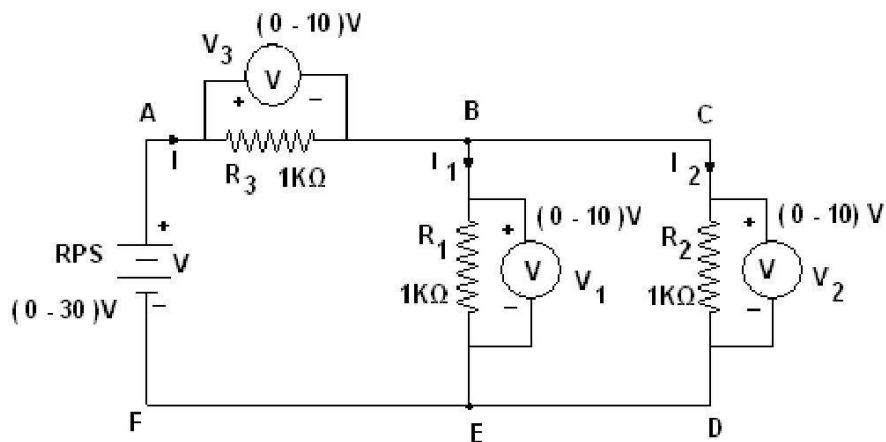

Circuit Diagram for Kirchoff's Voltage Law

PROCEDURE:

KIRCHOFF'S VOLTAGE LAW:

1. The circuit connections are given as per the circuit diagram.
2. Switch ON the power supply.
3. Initially set 5V as input voltage from RPS.
4. The voltmeter readings are noted and the values are tabulated.
5. The same procedure is repeated for various values.

Table:

Let $V = 5V$

S.NO	Applied voltage	Voltage in Volts		
		V1	V2	V3

RESULT:

Thus the Kirchoff's Voltage Law (KVL) for the given circuit is verified.

KIRCHOFF'S CURRENT LAW

EX. NO: 2(b)

AIM:

To verify the Kirchoff's Current Law (KCL) for the given circuit.

APPARATUS REQUIRED:

S.NO	APPARATUS	TYPE	RANGE	QUANTITY
1	RPS	DC	(0-30)V	1
2	Resistor	-	1K Ω	3
3	Ammeter	DC	(0-30)mA	3
4	Bread board	-	-	1
5	Connecting wires	-	-	Few

FORMULA USED:

1. CURRENT DIVISION RULE:

$$I = \frac{\text{TOTAL CURRENT X OPPOSITE RESISTANCE}}{\text{TOTAL RESISTANCE}}$$

2. OHM'S LAW:

$$V = IR$$

Where, V = Voltage in Volts
 I = Current in Amperes
 R = Resister in Ohms

THEORY:

KIRCHOFF'S CURRENT LAW:

It states that the algebraic sum of the currents meeting at a node is equal to zero.

$$\sum \text{Current flow towards the node} = \sum \text{Current flow away from the node}$$

CALCULATION:

$$R_1 = 1\text{K}\Omega ; R_2 = 1\text{K}\Omega ; R_3 = 1\text{K}\Omega$$

$$R_T = R_3 + R_p$$

$$= R_3 + \frac{R_1 R_2}{R_1 + R_2}$$

$$I = \frac{V}{R_T}$$

Let $V = 5V$,

$$I_1 = \frac{I \cdot R_2}{R_1 + R_2}$$

At node B the current = $I = I_1 + I_2$

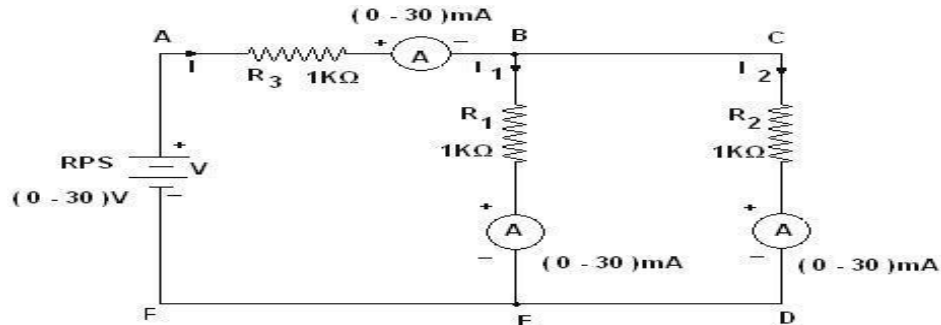

Circuit Diagram for Kirchoff's Current Law

PROCEDURE:

KIRCHOFF'S CURRENT LAW:

1. The circuit connections are given as per the circuit diagram.
2. Switch ON the power supply.
3. Initially set 5V as input voltage from RPS.
4. The ammeter readings are noted and the values are tabulated.
5. The same procedure is repeated for various values.

Table:

S.NO	Applied voltage	Current in amps		
		I1	I2	I=I1+I2

RESULT:

Thus the Kirchoff's Current Law (KCL) for the given circuit is verified.

VERIFICATION OF SUPERPOSITION THEOREM

EX. NO: 3

AIM:

To verify the superposition theorem for the given circuit.

APPARATUS REQUIRED:

S.NO	APPARATUS	TYPE	RANGE	QUANTITY
1	RPS	DC	(0-30)V	2
2	Resistor	-	1K Ω ,2K,10K	3
3	Ammeter	DC	(0-50)mA	1
4	Bread board	-	-	1
5	Connecting wires	-	-	Few

THEORY:

SUPERPOSITION THEOREM:

The superposition theorem for electrical circuits states that the total current in any branch of a bilateral linear circuit equals the algebraic sum of the currents produced by each source acting separately throughout the circuit.

To ascertain the contribution of each individual source, all of the other sources first must be "killed" (set to zero) by:

1. replacing all other voltage sources with a short circuit (thereby eliminating difference of potential. i.e. $V=0$)
2. replacing all other current sources with an open circuit (thereby eliminating current. i.e. $I=0$)

This procedure is followed for each source in turn, and then the resultant currents are added to determine the true operation of the circuit. The resultant circuit operation is the superposition of the various voltage and current sources

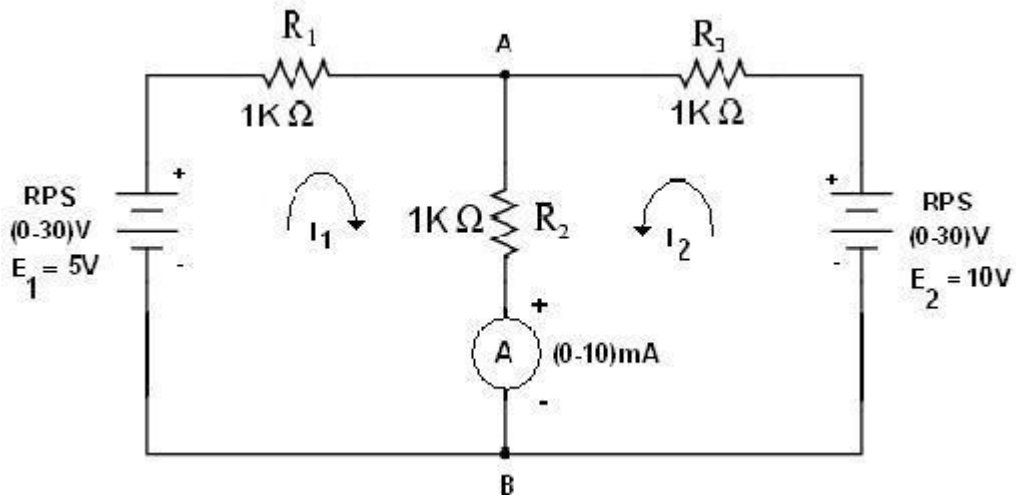

Circuit Diagram for Superposition Theorem

Table:

S.No	E1 voltage(Volts)	E2 voltage(Volts)	Load current across the branch AB (mA)	
			Theoretical	Practical
1				

E1 SOURCE IS

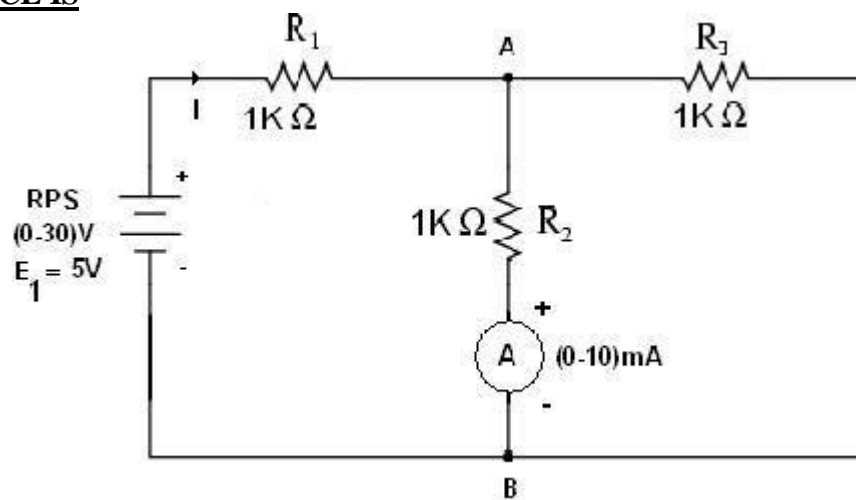

CALCULATION:

$$R_1 = 1K\Omega ; R_2 = 1K\Omega ; R_3 = 1K\Omega$$

$$R_T = R_1 + R_p$$

$$= R_1 + \frac{R_2 R_3}{R_2 + R_3}$$

$$I = \frac{V}{R_T}$$

Let $V = 5V$,

$$I_{AB1} = I \times \frac{R_3}{R_2 + R_3} = 3.3 \times 10^{-3} \times \frac{1000}{1000 + 1000}$$

Table:

S.No	E1 voltage(Volts)	Load current across the branch AB (mA)	
		Theoretical	Practical
1	5		

E2 SOURCE IS ACTING:

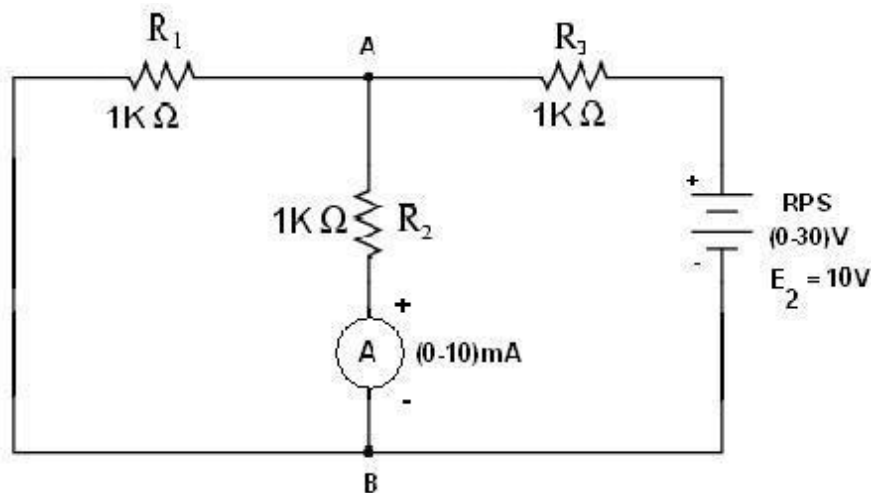

CALCULATION:

$$R_1 = 1K\Omega ; R_2 = 1K\Omega ; R_3 = 1K\Omega$$

$$R_T = R_3 + R_p \\ = R_3 + \frac{R_1 R_2}{R_1 + R_2}$$

$$I = \frac{V}{R_T}$$

Let $V = 10V$,

$$I_{AB2} = I \times \frac{R_3}{R_2 + R_3} = 6.66 \times 10^{-3} \times \frac{1000}{1000+1000}$$

Table:

S.No	E2 voltage(Volts)	Load current across the branch AB (mA)	
		Theoretical	Practical
1	10		

E1 and E2 SOURCES ARE ACTING:

$$I_{AB} = I_{AB1} + I_{AB2}$$

RESULT:

Thus the superposition theorem for the given circuit is verified.

VERIFICATION OF MAXIMUM POWER TRANSFER THEOREM

EX. NO: 4(a)

AIM:

To verify the maximum power transfer theorem for the given circuit.

APPARATUS REQUIRED:

S.NO	APPARATUS	TYPE	RANGE	QUANTITY
1	RPS	DC	(0-30)V	1
2	Resistor	-	1K Ω	2
3	Variable Resistor		1K Ω	1
4	Ammeter	DC	(0-10)mA	1
5	Bread board	-	-	1
6	Connecting wires	-	-	Few

THEORY:

MAXIMUM POWER TRANSFER THEOREM:

In electrical engineering, the **maximum power (transfer) theorem** states that, to obtain maximum external power from a source to a load with a finite internal resistance, the resistance of the load must be made the same as that of the source.

The theorem applies to maximum power, and not maximum efficiency. If the resistance of the load is made larger than the resistance of the source, then efficiency is higher, since most of the power is generated in the load, but the overall power is lower since the total circuit resistance goes up.

If the internal impedance is made larger than the load then most of the power ends up being dissipated in the source, and although the total power dissipated is higher, due to a lower circuit resistance, it turns out that the amount dissipated in the load is reduced.

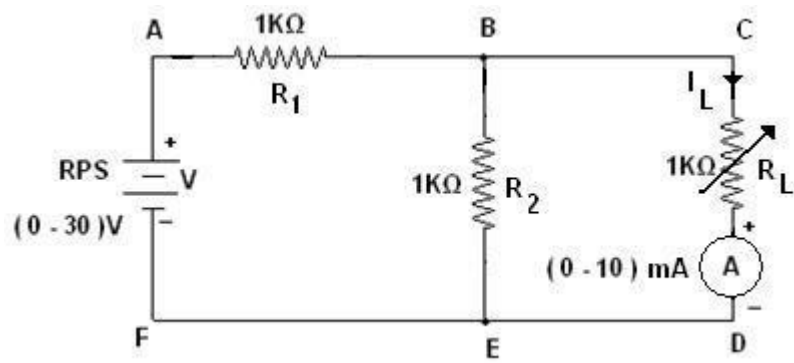

Circuit Diagram for Maximum Power Transfer Theorem

CALCULATION:

To Find RTH:

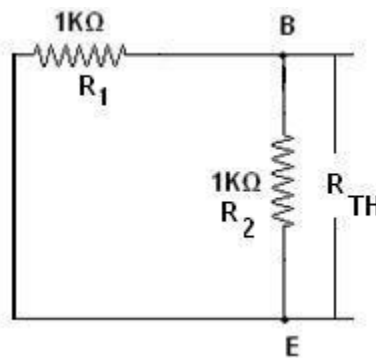

$$R_1 = 1\text{K}\Omega ; R_2 = 1\text{K}\Omega ;$$

$$R_{TH} = \frac{R_1 R_2}{R_1 + R_2} = \frac{1000 \times 1000}{1000 + 1000}$$

To Find VTH:

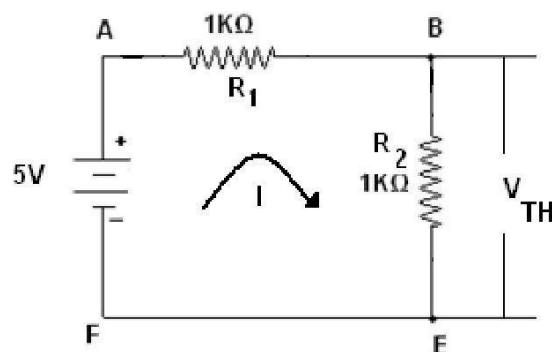

$$I = \frac{V}{R_T}$$

Let $V = 5V$,

$$V_{TH} = V_{BE} = 5 - 1K \times I$$

$$\therefore I_L = \frac{V_{TH}}{2 \times R_{TH}} = \frac{2.5}{2 \times 500} = 2.5mA$$

$$\therefore P_{max} = I_L^2 \times R_{TH} = 2.5 \times 10^{-3} \times 2.5 \times 10^{-3} \times 500$$

\therefore Load Resistance $R_L =$

PROCEDURE:

1. The circuit connections are given as per the circuit diagram.
2. Switch ON the power supply.
3. Initially set 5V as input voltage from RPS.
4. The ammeter reading is noted for various values of load resistance and the values are tabulated.
5. The load resistance for the maximum power is obtained from the table.

Table:

Let $V = 5V$

S.No	Resistance(RL) in Ohms	Current(IL) in mA	Power (IL ² RL) in mW
1	100		
2	200		
3	300		
4	400		
5	500		
6	700		
7	900		

RESULT:

Thus the maximum power transfer theorem for the given circuit is verified successfully.

RECIPROCITY THEOREM

EX. NO: 4(b)

AIM:

To verify the reciprocity theorem for the given circuit.

APPARATUS REQUIRED:

S.NO	APPARATUS	TYPE	RANGE	QUANTITY
1	RPS	DC	(0-30)V	1
2	Resistor	-	1K Ω	4
3	Ammeter	DC	(0-5)mA	1
4	Bread board	-	-	1
5	Connecting wires	-	-	Few

THEORY:

RECIPROCITY THEOREM:

The reciprocity theorem states that if an emf 'E' in one branch of a reciprocal network produces a current I in another, then if the emf 'E' is moved from the first to the second branch, it will cause the same current in the first branch, where the emf has been replaced by a short circuit. We shall see that any network composed of linear, bilateral elements (such as R, L and C) is reciprocal.

Before interchanging:

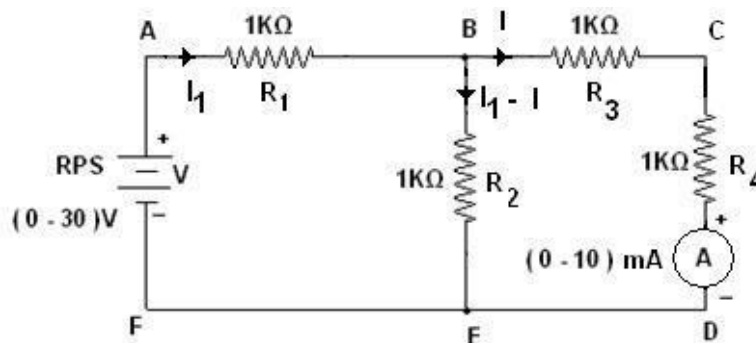

Circuit Diagram for Reciprocity Theorem

CALCULATION:

Let $V=5V$

In the loop ABEF by applying KVL,

$$I_1 R_1 + (I_1 - I) R_2 = V$$

$$I_1 \times 1 + (I_1 - I) \times 1 = 5$$

$$2I_1 - I = 5 \text{ -----(1)}$$

In the loop BCDE by applying KVL,

$$I R_3 + I R_4 - (I_1 - I) R_2 = V$$

$$I \times 1 + I \times 1 - (I_1 - I) \times 1 = 0$$

$$-I_1 + 3I = 0 \text{ -----(2)}$$

$$D = \begin{vmatrix} 2K & -1K \\ -1K & 3K \end{vmatrix} = 6K^2 - 1K^2 = 5K^2 = 5 \times 10^6$$

$$D_2 = \begin{vmatrix} 2K & 5 \\ -1K & 0 \end{vmatrix} = 5K = 5 \times 10^3$$

$$I = \frac{D_2}{D} = \frac{5 \times 10^3}{5 \times 10^6} = 1mA$$

PROCEDURE:

1. The circuit connections are given as per the circuit diagram.
2. Switch ON the power supply.
3. Initially set 5V as input voltage from RPS.
4. The ammeter reading is noted and tabulated.

Table for before interchanging:

V (Volts)	Current (mA)	
	Theoretical	Practical
5		

After interchanging:

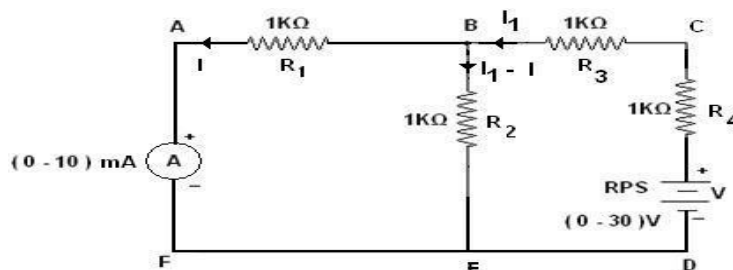

Circuit Diagram for Reciprocity Theorem

CALCULATION:

Let V=5V.

In the loop ABEFA by applying KVL,

$$I R_1 - (I_1 - I) R_2 = V$$

$$I \times 1 - (I_1 - I) \times 1 = 0$$

$$-I_1 + 2I = 0 \text{ -----(1)}$$

In the loop BCDE B by applying KVL,

$$I_1 R_4 + I_1 R_3 + (I_1 - I) R_2 = V$$

$$I_1 \times 1 + I_1 \times 1 + (I_1 - I) \times 1 = 5$$

$$3I_1 - I = 5 \text{ -----(2)}$$

$$D = \begin{vmatrix} -1K & 2K \\ 3K & -1K \end{vmatrix} = 1K^2 - 6K^2 = -5K^2 = -5 \times 10^6$$

$$D_2 = \begin{vmatrix} -1K & 0 \\ 3K & 5 \end{vmatrix} = -5K - 0 = -5 \times 10^3$$

$$I = \frac{D_2}{D} = \frac{-5 \times 10^3}{-5 \times 10^6} = 1mA$$

PROCEDURE:

1. The circuit connections are given as per the circuit diagram.
2. Switch ON the power supply.
3. Initially set 5V as input voltage from RPS.
4. The ammeter reading is noted and tabulated.

Table for before interchanging:

V (Volts)	Current (mA)	
	Theoretical	Practical
5		

RESULT:

Thus the reciprocity theorem for the given circuit is verified successfully.

**DETERMINATION OF RESONANCE FREQUENCY OF SERIES AND
PARALLEL RLC CIRCUITS**

EX. NO: 5

AIM:

To determine the resonance frequency of series and parallel RLC circuits

APPARATUS REQUIRED:

S.NO	APPARATUS	TYPE	RANGE	QUANTITY
1	Function Generator	AC	(1Hz-3MHz)	1
2	Resistor	AC	600Ω	1
3	Inductor	AC	101.4mH	1
4	Capacitor	AC	0.01mF	1
5	Ammeter	AC	(0-10)mA	1
6	Bread board	-	-	1
7	Connecting wires	-	-	Few

THEORY:

The resonance of a RLC circuit occurs when the inductive and capacitive reactance are equal in magnitude but cancel each other because they are 180 degrees apart in phase. The sharp minimum in impedance which occurs is useful in tuning applications. The sharpness of the minimum depends on the value of R.

The frequency at which the reactance of the inductance and the capacitance cancel each other is the resonant frequency (or the unity power factor frequency) of this circuit. This occurs at

$$f_r = \frac{1}{2\pi\sqrt{LC}}$$

SERIES RESONANCE:

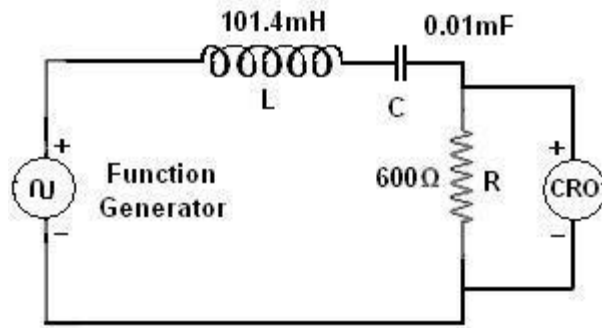

Circuit Diagram for Series Resonant

CALCULATION:

$$R = 600\Omega$$

$$L = 101.4\text{mH}$$

$$C = 0.01\mu\text{F}$$

∴ The resonant frequency is,

$$f_r = \frac{1}{2\pi\sqrt{LC}} = \frac{1}{2\pi\sqrt{101.4 \times 10^{-3} \times 0.01 \times 10^{-6}}} = 5 \text{ KHz}$$

PROCEDURE:

1. The circuit connections are given as per the circuit diagram.
2. Switch ON the power supply.
3. The input is given in the form of sin wave by function generator.
4. The amplitude of the response across the resistor is noted for various frequency ranges.
5. The current is calculated and tabulated.

Table:

S.No	Frequency (KHz)	Output voltage (Volts)	$I = V / R$ (mA)
1	1		
2	2		
3	2.5		
4	3		
5	4.5		
6	6		
7	7		
8	8		

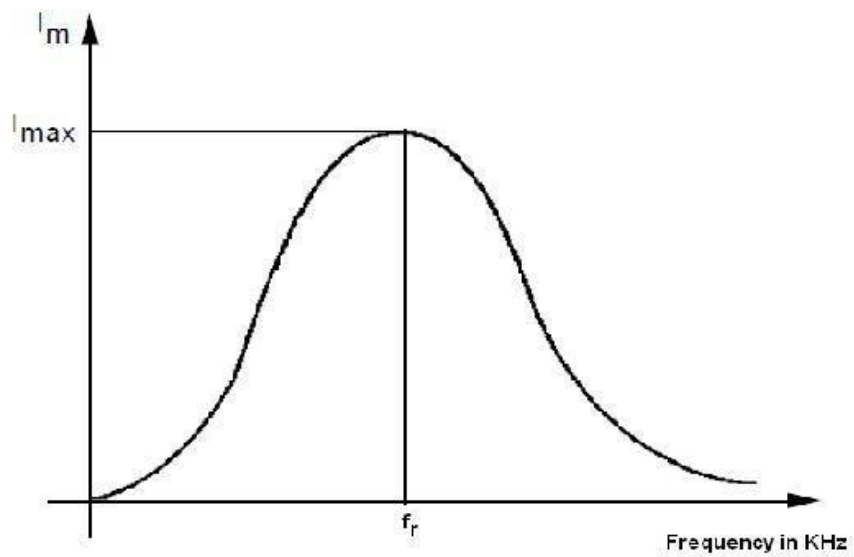

Frequency Response of Series Resonance Circuit

PARALLEL RESONANCE:

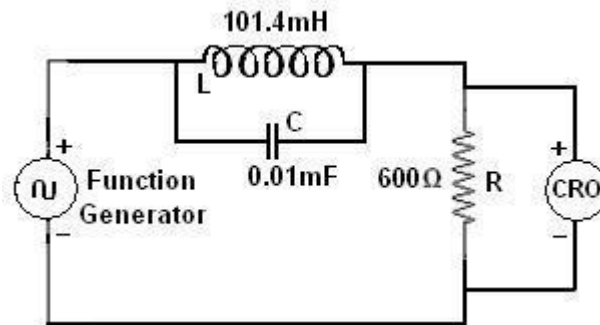

Circuit Diagram for Parallel Resonant

CALCULATION:

$$R = 600\Omega$$

$$L = 101.4\text{mH}$$

$$C = 0.01\mu\text{F}$$

∴ The resonant frequency is,

$$f_r = \frac{1}{2\pi\sqrt{LC}} = \frac{1}{2\pi\sqrt{101.4 \times 10^{-3} \times 0.01 \times 10^{-6}}} = 5 \text{ KHz}$$

PROCEDURE:

1. The circuit connections are given as per the circuit diagram.
2. Switch ON the power supply.
3. The input is given in the form of sin wave by function generator.
4. The amplitude of the response across the resistor is noted for various frequency ranges.
5. The current is calculated and tabulated.

Table:

S.No	Frequency (KHz)	Output voltage (Volts)	$I = V / R$ (mA)
1	1		
2	1.8		
3	2.5		
4	3		
5	4		
6	5.2		
7	7		
8	8		

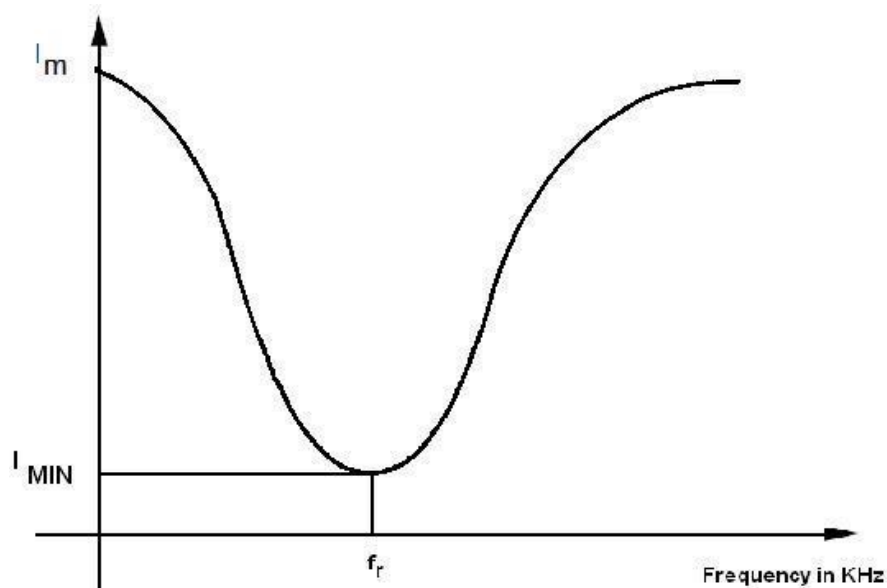

Frequency Response of Parallel Resonance Circuit

RESULT:

Thus the frequency response of series and parallel resonant circuits are analyzed.

TRANSIENT ANALYSIS OF RL AND RC CIRCUITS

EX. NO: 6

AIM:

To construct RL & RC transient circuit and to draw the transient curves.

APPARATUS REQUIRED:

S.NO	NAME OF THE EQUIPMENT	RANGE	TYPE	QTY.
1.	RPS	(0-30)V	DC	1
2.	Ammeter	(0-10)mA	MC	1
3.	Voltmeter	(0-10)V	MC	1
4.	Resistor	10 K Ω	-	3
5.	Capacitor	1000 μ F	-	1
6.	Bread board	-	-	1
7.	Connecting Wires	-	Single strand	As required

THEORY:

Electrical devices are controlled by switches which are closed to connect supply to the device, or opened in order to disconnect the supply to the device. The switching operation will change the current and voltage in the device. The purely resistive devices will allow instantaneous change in current and voltage.

An inductive device will not allow sudden change in current and capacitance device will not allow sudden change in voltage. Hence when switching operation is performed in inductive and capacitive devices, the current & voltage in device will take a certain time to change from pre switching value to steady state value after switching. This phenomenon is known as transient. The study of switching condition in the circuit is called transient analysis. The state of the circuit from instant of switching to attainment of steady state is called transient state. The time duration from the instant of switching till the steady state is called transient period. The current & voltage of circuit elements during transient period is called transient response.

FORMULA:

Time constant of RC circuit = RC

PROCEDURE:

- Connections are made as per the circuit diagram.
- Before switching ON the power supply the switch S should be in off position
- Now switch ON the power supply and change the switch to ON position.

CIRCUIT DIAGRAM:

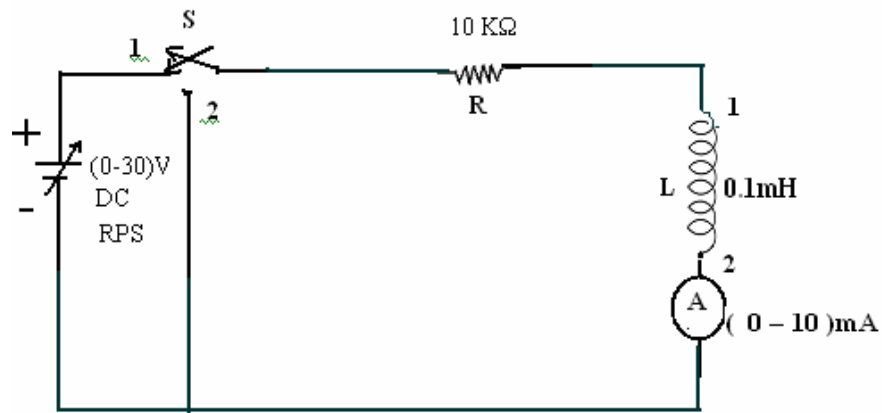

TABULATION:

S.NO.	TIME (msec)	CHARGING CURRENT (I) A	DISCHARGING CURRENT (I) A

MODEL CALCULATION & ANALYSIS:

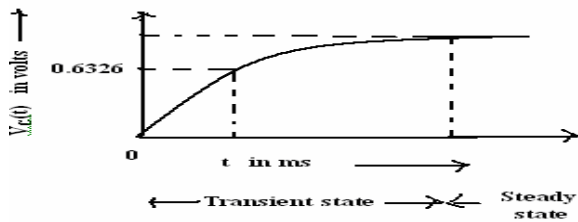

CIRCUIT DIAGRAM:

RC CIRCUIT:

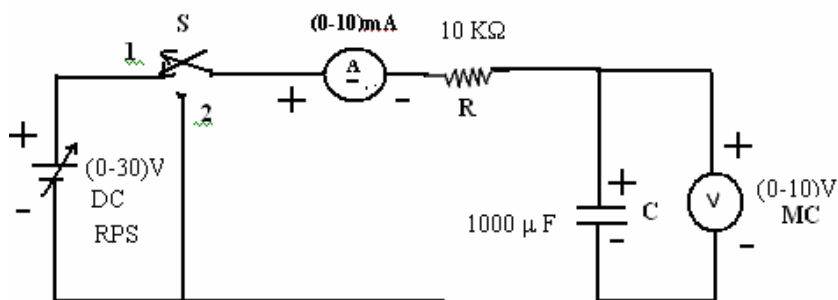

MODEL GRAPH:

CHARGING

DISCHARGING

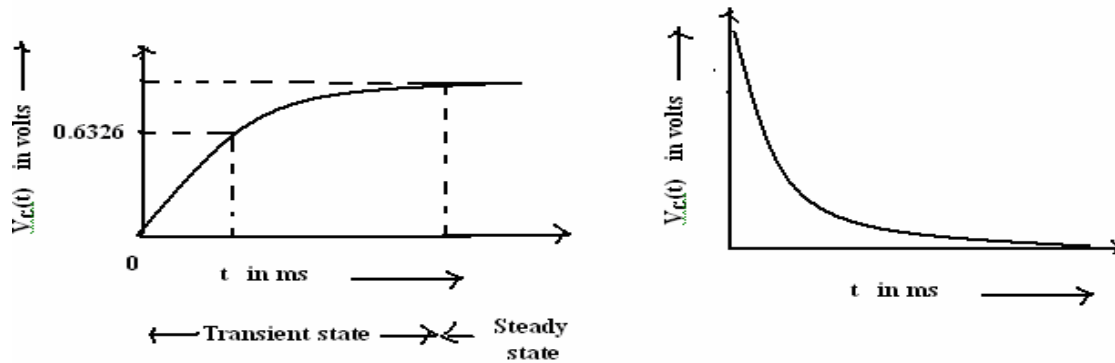

CHARGING:

S.NO.	TIME (msec)	VOLTAGE ACROSS 'C' (volts)	CURRENT THROUGH H'C' (mA)

MODEL CALCULATION & ANALYSIS:

TABULATION:

DISCHARGING:

S.NO.	TIME (msec)	VOLTAGE ACROSS 'C' (volts)	CURRENT THROUGH H'C' (mA)

MODEL CALCULATION & ANALYSIS:

RESULT:

Thus the transient response of RL & RC circuit for DC input was verified.